



EXCLUSIVE

SPIDER LIFTS AT A HIGHER LEVEL FOR 40 YEARS

FALCON 230Z
(FALCON 76Z)





The ultimate compact platform

The Falcon has an extremely versatile boom configuration and machine compactness which make the Falcon models the best choice for maintainers, pruners, installers and hires.

- Facility management
- Atrium access
- Narrow access
- Tree care
- Best quality & safety
- Easy transport & propelling
- Low weight & ground pressure
- Flexible outrigger setting
- Limited setup space
- Power - Bi-energy Hybrid

The Falcon is capable of passing through a door opening a mere 0,8 m (2'7") wide and 2 m (6'6") high. Further details on the Falcon 230Z (76Z) is mentioned on the following pages.





Model: Falcon 230Z Falcon 76Z

**Falcon 230Z
(Falcon 76Z)**

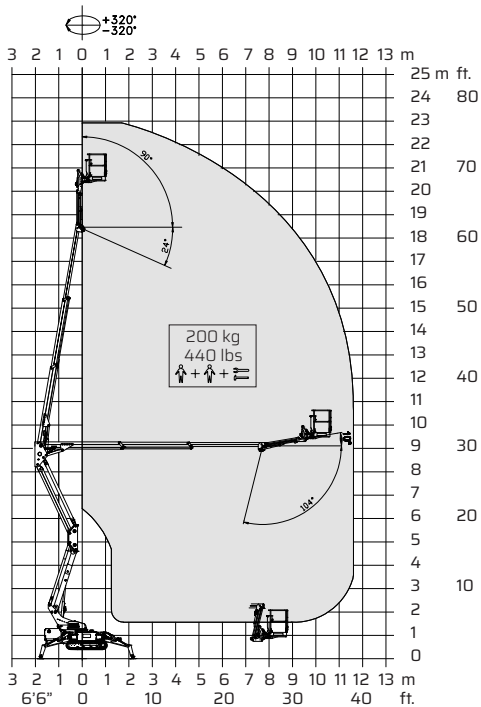

Working height and reach.

	Metric	US
Working height:	23 m	75'6"
Maximum reach:	12,0 m	39'4"
Basket load:	200 kg	440 lbs
Aluminium basket:	130x70x110 m	4'3"x2'4"x3'7"
Turret rotation:	+320° / -320°	+320° / -320°
Dimensions (transport position)		
Total height:	2,0 m	6'7"
Total length:	5,337 m	17'6"
Total width:	0,78 m	2'7"
Gradability:	31%	31%
Weight approx.:	2900 kg*	6380 lbs*

*Depending on optional equipment



FALCON LIFTS A/S

Tolderlundsvej 106
DK-5000 Odense C
Tel: +45 66 13 11 00

falcon@falconlifts.com
falconlifts.com

STANDARD EQUIPMENT:

- Articulated boom (two elements)
- Telescopic boom (main boom + 2 extensions)
- Jib
- $\pm 320^\circ$ turret rotation
- Engine start and stop controls from basket
- Basket with aluminium guardrails
- Basket rotation 180°
- Automatic basket levelling
- Basket load sensing device
- 4 hydraulic outriggers
- Power supply in basket
- Gradability approximately 31%
- Drive speed max 2 Km/h (1,25 mph)
- Wireless remote control
- AC 2,2 kW motor
- Flexible outrigger settings
- Hydraulic opening of outriggers
- Hour meter
- Standard boom colours Grey (RAL 7035) and chassis Blue (RAL5002)
- EN 280:2013 CE Certified
- ANSI Certified

Available with one of the following engines:

- Diesel (Kubota)

Or Lithium version

- Lithium batteries 48V 300 Ah (Falcon 230Z Lithium/
Falcon 76Z Lithium)

OPTIONS:

- Dust Cover for Storage
- Nylon plates for outrigger
- Special colour
- Anti entrapment device
- Non-marking crawlers
- Air/water in basket
- GSM module for remote access and monitoring

Video of Falcon 230Z

